

IntelliCon®-FA**FORCED-AIR HEATING SYSTEM ECONOMIZER****Description**

The IntelliCon®-FA is a patented microprocessor-based fuel-saving device for forced-air (warm-air) heating systems. The controller reduces fuel consumption and burner emissions by actively managing the burner, in conjunction with the thermostat, to operate the furnace in a more energy efficient manner. The controller indicates average theoretical savings. In addition, certain parameters are programmable. All of the programmable parameters and savings values are stored in memory that will not be lost in the event of the unit being turned off or a power failure.

This unit is not intended for use on milli-volt or self-powered gas burner systems.

Electric Ratings

Power input: 24,115,220 VAC ± 10%, 5 Watts max., 50/60Hz
Control circuit input: 24,115,220 VAC ± 10%, 0.1A max. Burden
Relay Contact: Form B, 10A @ 220 VAC (General Purpose)

Environmental Conditions

For Indoor Use
Maximum Altitude (2000M)
Rated Ambient Temperature 32 - 120°F. (0 - 49°C.)
Maximum Rh 90% non-condensing
Mains Supply Voltage Fluctuations ± 10%
Transient Over-Voltage Category (III)
Pollution Degree (2)

Operation

After installation, setting the switch on the unit to the 'ON' position activates the control. The LCD display indicates the various 'modes' of operation of the control, sensed temperatures, savings and economizer and burner run-times. The possible messages and their explanation are:

STANDBY MODE

The space temperature is satisfied and the thermostat is not calling for the furnace to fire.

BURNER ENABLED

The thermostat is calling for the burner to fire and the controller is allowing the burner to fire.

Note: A period (.) or colon (:) may be appended to the message.

. = The period signifies that the Discharge-Air Terminal Temperature has been established.

: = The colon indicates that the Maximum Economizer Hold-Off timer has enabled the burner.

ECONOMIZING

The controller has turned the burner Off even though the thermostat is calling for the burner to fire.

During normal operation, one of the above messages will be alternated with the messages below.

DA TEMP = OR **DA = xxx° RA = xxx°**

"DA TEMP = xxx" - The measured value of the furnace's discharge-air temperature is displayed in degrees F or C (see Programming section). *This message will NOT appear if the optional sensor is installed*

"DA = xxx° RA = xxx°" - The measured value of both the discharge and return air temperatures in degrees F or C (see Programming section). *This message will only appear if the optional sensor is installed (see "Sensors" section of these instructions).*

In the event that the unit detects a sensor fault, full control of the burner is returned to the existing controls. The 'Power/Normal' indicator will blink, and the following message will be displayed:

CHECK ?? SENSOR ?? = DA and/or RA

If this message appears, see the instructions under **Service and Troubleshooting**.

A SAV = xx.x%

The calculated average savings of burner cycles since commissioning of the controller (A = Average).

Note: This message will indicate N/A until there is sufficient data to perform the calculations.

ET HRS = xxxxx.x

Total hours of Economizer time. (maximum = 65,535.9 hours).

RT HRS = xxxxx.x

Total hours of Burner run-time. (maximum = 65,535.9 hours).

Installation

The controller is electrically installed in series with the burner control device as shown in the wiring diagrams contained in these instructions. Check and determine the voltages of the burner control circuit and power circuit prior to installation. **FOR SAFETY, POWER TO THE FURNACE MUST BE DISCONNECTED DURING INSTALLATION.**

Positioning

The unit must be protected from the elements and may be mounted on the equipment either vertically or horizontally. The unit should be mounted directly on the existing electric enclosure via the unit's standard ½" electrical fitting or within the enclosure using an accessory mounting bracket. For mounting in the elements, a rain-tight mounting enclosure is available.

Wiring

All wiring and connections must comply with Local and National Electrical Codes. The unit should be wired as shown in the wiring diagram(s) on the reverse side. It is important to read all of the instructions. Ensure that POWER TO THE UNIT IS OFF DURING INSTALLATION and that all unused leads are individually taped/insulated.

Sensors

Mount the discharge air sensor on the Furnace's discharge air ductwork/plenum as close to the furnace as possible but at least 18" from the heat-exchanger. Locate an unobstructed area on the ductwork/plenum and (**making sure there is nothing behind it**) drill a 5/8" dia. hole for the sensor to extend into the airflow. Attach the mounting bracket to the duct using # 8 hardware. If the sensor is installed exposed to the elements or mounted within the ductwork, the sensor must be installed using the optional rain-tight enclosure kit which may be obtained from Intellidyne (part no. 4066). Make sure that the sensor is oriented according to the direction of airflow as shown on the mounting diagram. Plug the sensor's connector into the '**Discharge Air**' jack located on the side of the unit.

Additional economies can be realized through the use of a return air temperature sensor. Mount the return air sensor on the Furnace's return air duct in a similar fashion to that of the discharge air sensor. Plug the sensor's connector into the '**Return Air**' jack located on the side of the unit.

The controller will not work without the discharge air sensor and will work improperly if the plugs are in the wrong jacks. Use of the return air sensor is optional but should be used whenever possible.

Checkout

Recheck wiring one last time and make sure that the temperature sensor(s) is plugged into the proper jack(s). The sensors are only detected during power-up. Set the controller to 'Off/Bypass' and restore power to the furnace. Note the thermostat setting and then change that setting all the way down. Place the switch on the controller to 'On'. After a brief check of the electronics, the sensor(s) will be detected and the green 'Power/Normal' indicator should light continuously. It is important to verify recognition of the sensors by viewing the temperature reading(s), on the display. If the installed sensor(s) are not detected, the unit will not function properly. If the green indicator is blinking or if the display does not verify the installed sensor(s), turn the unit 'Off' and check the sensor installation. After the sensor-check, verify that the unit is in **STANDBY MODE**. If in **STANDBY MODE**, force a heat call (burner to fire) by temporarily raising the thermostat all the way up and verifying that the unit changes to **BURNER ENABLED** mode and that the burner fires. **Make sure to return the thermostat to its' original setting.** This indicates that the control is operating normally. If the unit did not change modes and the burner fire when the thermostat was adjusted the unit is probably wired incorrectly.

Service and Troubleshooting

After Installation and Checkout, the controller requires no maintenance and will provide years of trouble free operation. The unit may be disconnected at any time by placing the slide switch in the 'Off/Bypass' position. In this position, the unit has no effect on the system and the burner is controlled as it was prior to the controllers installation. This allows service personnel to troubleshoot or work on the furnace without the controller intervening.

If at any time the light on the front panel blinks continuously, a sensor is not operating properly.

If the message **LINE SYNC FAILED** **SYSTEM BYPASSED** is displayed the control should be placed into the OFF/Bypass position.

If any of the above trouble conditions have occurred the control has taken itself out of the circuit and returned full control to the pre-existing controls. The Installer should be called for service.

IntelliCon®-FA

FORCED-AIR HEATING SYSTEM ECONOMIZER

**IMPORTANT - READ CAREFULLY**

1. Failure to follow these instructions may result in damage to the system or cause a hazardous condition.
2. Installer must be experienced, qualified, and in certain locations, licensed to work on the system that this control is being installed on.
3. After installation is complete, follow the check-out procedure as provided in these instructions to confirm proper system operation.
4. Intellidyne is not responsible for improper installation or any damages that may result from improper installation.
5. Actual wiring may differ from that shown in the diagrams.
6. Equipment may have controls not shown.
7. Because the IntelliCon can operate with different voltages for the power and control circuits, it has separate common wires for these circuits. It is necessary that these wires are connected to the proper commons or the unit will not function properly. See the wiring diagrams contained in these instructions for details.

IMPROPER VOLTAGE SELECTION MAY DAMAGE THE UNIT AND VOID THE WARRANTY.

PROGRAMMING

The following parameters may be changed in the field by following these instructions.

Pre-Purge time and Temperature indication in either degrees F or C.

It is very important that if there is any kind of a delay (more than ten (10) seconds), from the time that the thermostat calls for the burner to start and the burner actually starts, that this time delay value be entered into the controller as a Pre-Purge time (e.g. actual pre-purge timer, Flue Damper interlock, etc.). If there is a delay and the correct value is not programmed into the controller, the savings calculations will be incorrect.

ALL PROGRAMMING IS ACHIEVED BY INSERTING AND REMOVING A TEMPERATURE SENSOR PLUGGED INTO THE RETURN-AIR SENSOR CONNECTOR, WHEN DIRECTED TO DO SO VIA THE DISPLAY ON THE CONTROLLER. THE SENSOR MUST BE CONNECTED TO THE CABLE OR THIS WILL NOT WORK!

YOU HAVE TEN (10) SECONDS TO RESPOND TO ANY OF THE DISPLAY PROMPTS. THE 10 SECOND COUNTDOWN IS DISPLAYED ON THE CONTROLLER'S LCD DISPLAY.

PROGRAMMING MAY BE STOPPED OR ABORTED AT ANY TIME BY TURNING THE CONTROLLER OFF. ANY PARAMETERS THAT WERE CHANGED WILL REMAIN CHANGED.

Entering Configuration Mode:

To enter configuration mode, the controller must be powered up without any sensors connected. When prompted insert a sensor plug into the RETURN-AIR sensor connector. To confirm, remove the plug when prompted.

Any changes made to a programmable parameter will be confirmed by indicating **"DATA SAVED"** before advancing to the next parameter.

RESET DEFAULTS?

This parameter will reset all of the programmable parameters to factory defaults. It will not clear any of the accumulators.

RESET TIMERS?

This parameter will clear the Economizer and Burner Run-Time accumulators.

PREPURGE=xxx SEC

This parameter indicates the pre-purge time currently programmed into the controller (default value = 000 seconds). Next you will be prompted to change by inserting the sensor plug within 10 seconds. If not inserted within the 10 seconds the controller will advance to the next programmable parameter (For Degrees F or C). If inserted you will be prompted to force a burner call, typically done by increasing the set-point of the thermostat, and then to remove the sensor plug when the burner starts. When prompted to "FORCE A HEATING CALL" the controller will wait indefinitely (NO 10 second time-out) for the CALL. So it is not necessary to rush.

FOR DEGREES C**OR FOR DEGREES F**

The controller will prompt you to change to whatever value is NOT currently selected (default value = F). For example, if the parameter is currently set for degrees F, the only choice will be to change to degrees C. This setting will alter how the indicated temperatures are displayed when the controller is in operation.

DAT MAX = ??????

This feature of the controller allows the user to set or limit the Maximum Air Temperature being discharged from the unit. The allowable values are 90° - 150° F (32° - 65° C), AUTO, and DISABLED. To change this setting, plug in the sensor when prompted. The indicated value will be what is currently set in the controller (default = DISABLED). Next the controller will count up until the maximum settable value is reached and then roll over to the lowest. Remove the sensor when the desired value is reached. *It is recommended that this be set to Disabled. If you feel that this must be changed, it should be discussed with technical support.*

MAX ECON = xxx MIN**OR MAX ECON = DISABLD**

This feature of the controller is to limit the maximum amount of time that the controller is allowed to hold the Burner OFF. To change this setting, plug in the sensor when prompted. The indicated value will be what is currently set in the controller (default = 3 minutes). Next the controller will count up until the maximum settable value is reached (10 minutes), then "DISABLED", and then will jump to the minimum settable value (1 minute). Remove the sensor when the desired value is reached.

ECON TIMER OFF?**OR ECON TIMER ON?**

This parameter controls whether or not the Economizer Time accumulator is displayed. The controller will prompt you to change to whatever value is NOT currently selected (default value = ON). For example, if the parameter is currently set for "ON", the only choice will be to change to "OFF". Note – the accumulator is active even if not displayed.

RUN TIME OFF?**OR RUN TIME ON?**

This parameter controls whether or not the Burner Run-Time accumulator is displayed. The controller will prompt you to change to whatever value is NOT currently selected (default value = ON). For example, if the parameter is currently set for "ON", the only choice will be to change to "OFF". Note – the accumulator is active even if not displayed.

A SAVING OFF?**OR A SAVING ON?**

This parameter controls whether or not the Average Savings accumulator is displayed. The controller will prompt you to change to whatever value is NOT currently selected (default value = ON). For example, if the parameter is currently set for "ON", the only choice will be to change to "OFF". Note – the accumulator is active even if not displayed.

LATCH MODE = ON?**OR LATCH MODE = OFF?**

This is a special application feature that should NOT be used without conferring with Technical Support (Default = OFF).

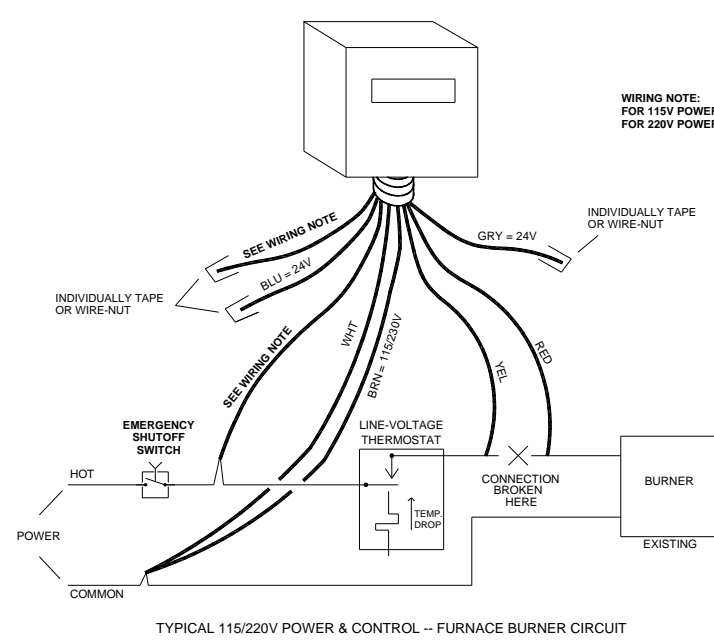

Fig. 1a

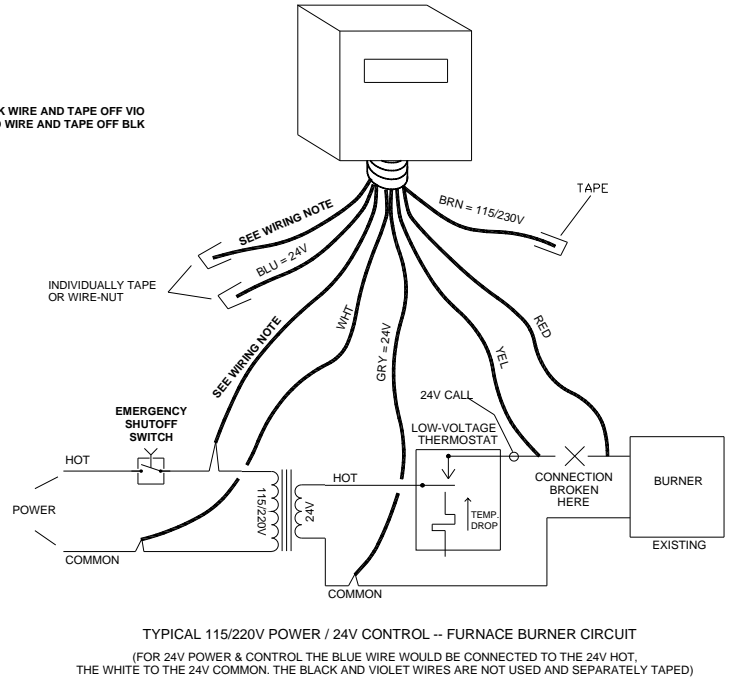

Fig. 1b

WIRING NOTE: The IntelliCon unit has MULTI-VOLTAGE capability and has separate common wires for the Power and Control circuits. It is necessary that these wires be connected to the appropriate commons for the circuit or the unit will not function properly. Unused wires **MUST** be separately taped!
IMPROPER VOLTAGE SELECTION WILL DAMAGE THE UNIT and Void the Warranty.

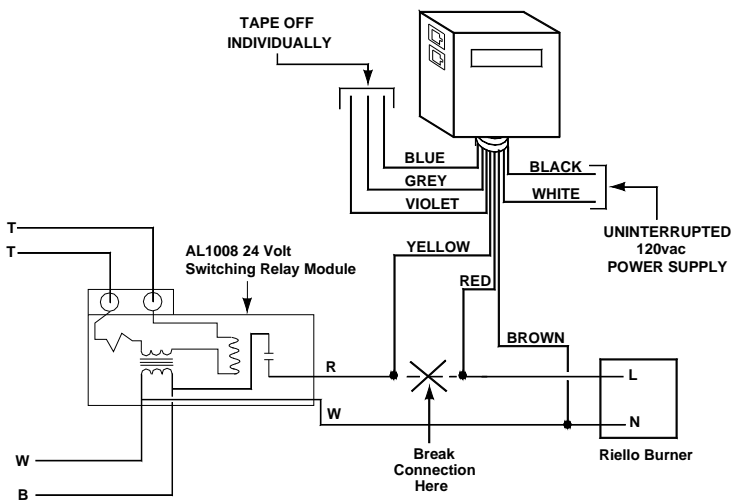

Fig. 1c

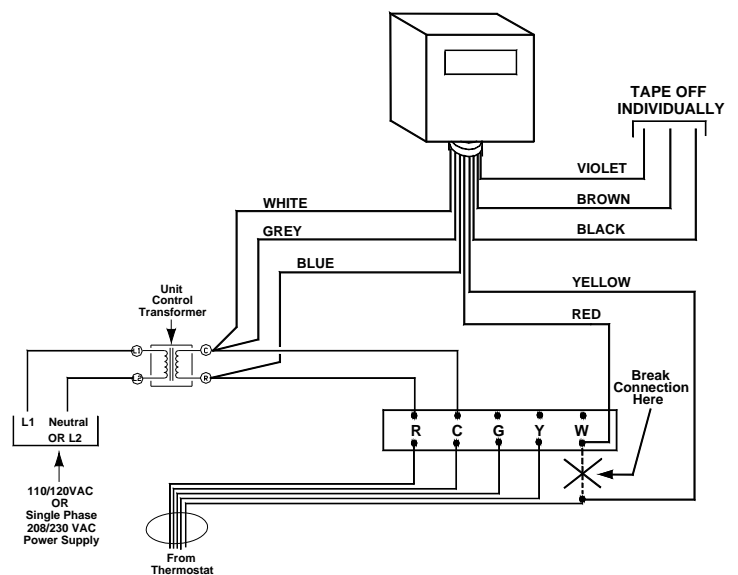
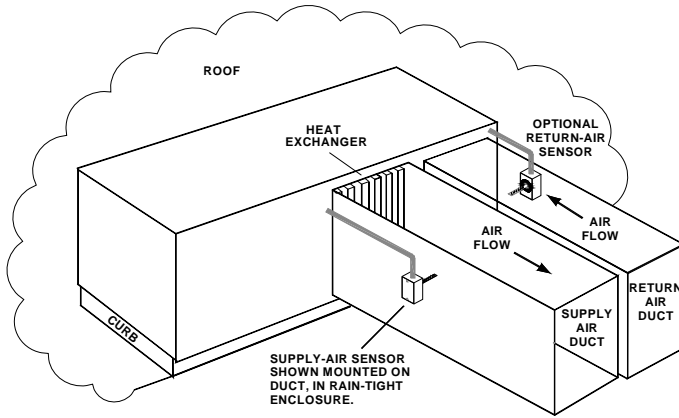

Fig. 1d



TYPICAL SIDE OR END-FLOW
 DISCHARGE ROOF-TOP UNIT



TYPICAL DOWN-FLOW DISCHARGE
 ROOF-TOP UNIT

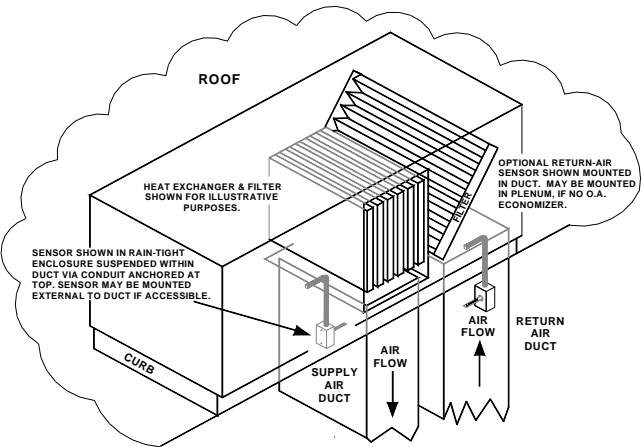

TYPICAL TOP DISCHARGE RESIDENTIAL UNIT

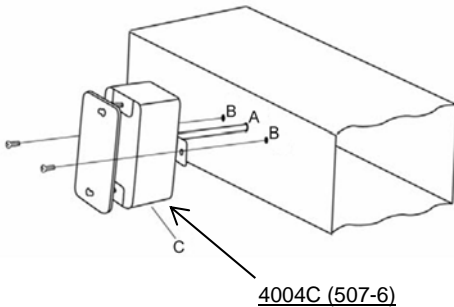
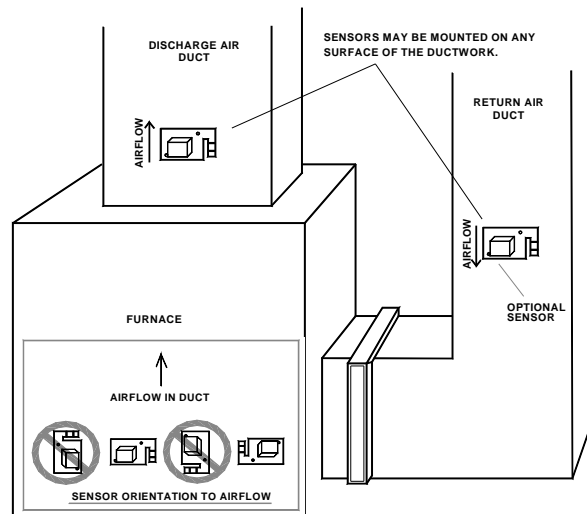

4004B, 4004C SENSOR MOUNTING

Note: This sensor is NOT air-flow direction sensitive

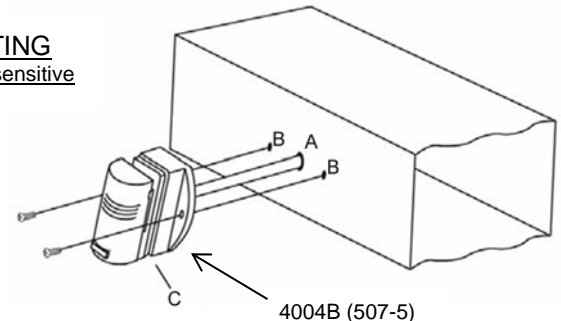

1. Drill a 1/4" hole in the duct away from temperature stratified air, coils or humidifiers. Insert the probe into the duct (A).
2. Drill two 1/8" pilot holes through the holes in mounting flange (B). Use two # 8 galvanized or stainless steel sheet-metal screws and securely fasten the sensor to the duct. Do not over tighten.
3. We recommend mounting the sensor with the cable inlet facing down.
4. Run control wires through cable inlet (C) and attach wires to the quick connect terminals. The connections are not polarity or position sensitive. Attach cover to sensor.