

# OPERATING MANUAL and INSTALLATION INSTRUCTIONS for **IntelliCon®-HW+** HOT-WATER HEATING SYSTEM ECONOMIZER

Form HW+3250 rev 7.2



## Description

The IntelliCon®-HW+ is a patented microprocessor-based fuel-saving controller for hydronic heating systems up to 300M BTUs. It reduces fuel consumption, wear on boiler parts and burner emissions by actively managing the burner, in conjunction with the boiler operating-control, to properly match the boiler output to the required load. This controller indicates actual savings on a burner cycle by cycle basis and also indicates the averages of these cycles. This unit is compatible with Intellidyne's Remote Display Unit (model RDU). In addition, certain parameters are programmable. All of the programmable parameters and savings values are stored in memory that will not be lost in the event of the unit being turned off or a power failure.

## Electric Ratings

Power input: 24,115,220 VAC ± 10%, 5 Watts max., 50/60Hz  
Control circuit input: 24,115,220 VAC ± 10%, 0.1A max. Burden  
Relay Contact: Form B, 10A @ 220 VAC (General Purpose)

## Environmental Conditions

For Indoor Use.  
Maximum Altitude: 6500 Ft. (2000M)  
Rated Ambient Temperature: -20° -- 120° F. (-29° -- 49° C.)  
Maximum Rh: 80% non-condensing  
Mains Supply Voltage Fluctuations: ± 10%  
Transient Over-Voltage Category: (III)  
Pollution Degree: (2)

**Note: The IntelliCon control must be operated within the specifications and protected from the elements. Failure to do so voids the warranty and guarantee. Below 32°F (0°C), the control will continue to operate but the LCD display may not function properly. The display will return to normal above that temperature.**

## Operation

After installation, setting the switch on the controller to the 'ON' position activates the control. The LCD display indicates the various 'modes' of the device, sensed temperatures, and percent savings. The possible messages and their explanation are:

### STANDBY MODE

The boiler is operating under its own internal operating-control, which has turned the burner off. This occurs for a period of time after the burner has shut down.

### ECONOMIZER MODE

The boiler operating-control has requested the burner to come on but the controller has sensed that there is available heat which can be used without burning fuel. The burner will remain off and useful heat will be delivered from the boiler's existing supply of residual heat.

### HEATING MODE

The controller has released the burner to fire.

### HEATING / LO LIM

The controller has released the burner to fire due to a load condition that has caused the water temperature to go below the programmed low limits. This condition may occur occasionally. If this message appears frequently, the boiler operating-control may need to be increased in 5°F (3°C) increments until the condition stops or the "low limits" may need to be adjusted (see Programming section)

**During normal operation, one of the above messages will be alternated with the message(s) below.**

### HEAT TEMP = xxx°F

The measured value of the boiler outflow water temperature is displayed in °F (may be programmed for °C).

### DOM TEMP = xxx°F

The measured value of the domestic hot water outflow temperature is displayed in °F (may be programmed for °C). This message will only

appear if the boiler supplies domestic hot water and the optional second sensor is installed (see Sensor Section of these instructions).

### A SAVE = xx.x%

The calculated average savings of all burner cycles since commissioning of the controller. The option to display this screen is programmable (Default = ON). **Note: The numeric value will not be displayed until a value that is greater than zero is calculated.**

### ST HRS = xxxxx.x

Total hours of Standby time. (maximum = 99,999.9 hours).

### ET HRS = xxxxx.x

Total hours of Economizer time. (maximum = 99,999.9 hours). The option to display this screen is programmable (Default = ON).

### RT HRS = xxxxx.x

Total hours of Burner run-time. (maximum = 99,999.9 hours). The option to display this screen is programmable (Default = ON).

## Installation

The controller is electrically installed in series (**NEVER IN PARALLEL**) with the boiler operating-control as shown in the wiring diagrams on the back page of these instructions. It is very important that it be installed, electrically, before any interlocks to ensure proper operation of the burner and to eliminate any alarm or fault conditions that could be caused by the IntelliCon controller holding the burner off. **AT NO TIME SHOULD ANY SAFETY CONTROLS OR CIRCUITS BE CIRCUMVENTED.** Check and determine the voltages of the burner control circuit and power circuit prior to installation.

*To ensure maximum savings and proper operation, the following recommended settings should be made:*

For Single Aquastats – HLOLIM should be set 15°F (9°C) below the aquastat setpoint minus the differential setting. (e.g. for an aquastat with a setpoint of 170°F, with a 10°F differential the HLOLIM setting should be: 170°-10°-15°=145°). The DLOLIM should be set to the minimum desired temperature of the Domestic Hot-Water (if Domestic sensor is used).

For Dual or Triple Aquastats: The HLOLIM parameter should be set 5°F (3°C) below the setting of the "B" stat. The DLOLIM parameter should be set 20°F (12°C) below the setting of the "B" stat.

These values can be seen during power-up and are programmable.

## Positioning

The unit may be mounted on the equipment either vertically or horizontally. For readability of the display, the vertical position is preferred. The unit should be mounted directly on the existing electric enclosure via the unit's standard ½" electrical fitting or surface mounted using the accessory mounting bracket.

## Wiring

**All wiring and connections must comply with Local and National Electrical Codes. The unit should be wired as shown in the wiring diagrams on the reverse side. It is important to read all of the instructions and the NOTE on the other side of these instructions. Ensure that POWER TO THE UNIT IS OFF DURING INSTALLATION and that all unused leads are individually taped/insulated.**

## Sensors

Insert the sensor wire plug into the 'Heating Water Sensor' connector located on the side of the unit. Mount the sensor on the boiler outflow pipe using tie-wraps (see Fig. 2) or other secure method as close to the boiler as possible. Make sure that the sensor makes good thermal contact with the pipe. Cover the sensor with a small piece of pipe insulation (not provided) and secure in place (see Fig. 3).



For boilers which also supply domestic hot water through an internal coil, plug in a second sensor to the 'Domestic Water Sensor' connector and mount the sensor on the domestic hot water outflow-pipe at the storage tank, if present, or at the boiler domestic water coil outlet-pipe, if no storage tank is used. Follow the same procedure to attach the sensor as used above for the 'Heating Water Sensor'. This sensor should not be used if the boiler does not heat the domestic hot water.

In the event that a sensor fails, the controller automatically goes into bypass mode and returns full control of the burner to the boiler's operating-control, the 'Power/Normal' indicator will blink, and the following message will be displayed to identify the faulty sensor:

"H SENSOR FAULT" and/or "D SENSOR FAULT", "SYSTEM BYPASSED"

**If this message appears check and replace the faulty sensor.**

#### IMPORTANT - READ CAREFULLY

1. Failure to follow these instructions may result in damage to the system or cause a hazardous condition.
2. Installer must be experienced, qualified, and in certain locations, licensed to work on the system that this control is being installed on.
3. After installation is complete, follow the check-out procedure as provided in these instructions to confirm proper system operation.
4. Intellidyne is not responsible for improper installation or any damages that may result from improper installation.
5. Actual wiring may differ from that shown in the diagrams.
6. Equipment may have controls not shown.
7. Because the IntelliCon can operate with different voltages for the power and control circuits, it has separate common wires for these circuits. It is necessary that these wires are connected to the proper commons or the unit will not function properly. See the wiring diagrams on the reverse side of this sheet for details.

#### IMPROPER VOLTAGE SELECTION MAY DAMAGE THE UNIT AND VOID THE WARRANTY.

#### Checkout

Recheck wiring one last time and make sure that the temperature sensor(s) is plugged into the proper connector(s). The sensor(s) are only detected during power-up. Set the controller's switch to 'Off/Bypass' and restore power to the boiler. Reset the controller's switch to 'On'. After a brief check of the electronics and displaying various parameters of the controller, the sensor(s) will be detected and the green 'Power/Normal' indicator should light continuously. It is important to verify recognition of the sensors by viewing the temperature reading(s), on the display. If the installed sensor(s) are not detected, the IntelliCon controller will not function properly. If the green indicator is blinking or if the display does not verify the installed sensor(s), turn the controller 'Off' and check the sensor installation. After the sensor-check, depending upon the temperature of the boiler water at power-up, the controller will go into one of its various modes. If the controller went into 'STANDBY MODE'; note the operating-control setting and force a burner call by temporarily adjusting the operating-control higher and verifying the change of mode of the controller to the 'ECONOMIZER MODE', 'HEATING MODE' or 'HEATING/LOLIM' mode. If the controller went in to the 'ECONOMIZER MODE' you can either wait for the water temperature to drop and for the controller to go into 'HEATING MODE' or 'HEATING/LOLIM', or by removing a sensor plug, the controller will go into bypass mode, and the burner should fire shortly thereafter. If, after adjusting the operating-control, the controller went directly into 'HEATING MODE' or 'HEATING/LOLIM' the burner should fire shortly thereafter. The burner should run continuously until the call from the operating-control is satisfied. Once satisfied, the burner should stop firing and the controller should go into the 'STANDBY MODE'. The controller and burner following the above sequence indicates a properly wired and functioning control. **Make sure that if the operating-control was previously adjusted, to return it to its' previous setting.** If the burner fires for a brief second then stops (even though the operating-control is calling for the burner to run) is likely caused by the Yellow and Red wires being reversed. If the controller does not come out of "STANDBY MODE" when the boiler's operating-control is calling for the burner to run, the unit is wired incorrectly. The likely cause in this situation is either a reversed Yellow and Red wire or an improperly connected 'common' connection for the control circuit. See the IMPORTANT note (number 7) above.

#### Service and Troubleshooting

After Installation and Checkout, the controller does not require maintenance and will provide years of trouble free operation. The unit may be taken out of the circuit at any time by placing the switch to the 'Off/Bypass' position. In this position, the unit has no effect on the system and the burner is controlled as it was prior to the IntelliCon controller's installation. This allows service personnel to troubleshoot or work on the system without the controller intervening.

If at any time the Power/Normal light on the front panel blinks continuously, a sensor is not operating properly and The IntelliCon® controller has automatically gone into 'bypass mode'.

If the message "TIMER FAULT" is displayed the switch should be placed into the OFF/Bypass position and service called.

If the burner is running and the control is in "STANDBY MODE" a problem exists and service should be contacted.

#### PROGRAMMING

The following parameters may be changed in the field by following these instructions. **Pre-Purge time, Temperature indication in either degrees F or C, Heating Water Low-Limit, Domestic Water Low-Limit, Maximum Economizer Hold-Off Time, Standby-Timer Override, and whether or not Standby Time, Economizer Time, Burner Run-Time, and A SAVINGS are Displayed.** The system may also be returned to factory default values and the Average Savings, Economizer Time, and Run-Time accumulators may be cleared.

All of the default values have been carefully selected to result in the greatest savings for the broadest scope of heating system applications. Individual system requirements may require changes. Please note that all of these programmable parameters will affect the amount of savings. Prudent changes are strongly advised.

It is very important that if there is any kind of a delay (more than fifteen (15) seconds), from the time that the Operating-control calls for the burner to start and the burner actually starts, that this time delay value be entered into the controller as a Pre-Purge time (e.g. actual pre-purge timer, Flue Damper interlock, etc.). If there is a delay and the correct value is not programmed into the controller, the savings calculations will be incorrect.

**ALL PROGRAMMING IS ACHIEVED BY PLUGGING AND UN-PLUGGING A WATER TEMPERATURE SENSOR INTO THE APPROPRIATE SENSOR-JACK. THE SENSOR MUST BE CONNECTED TO THE CABLE OR THIS WILL NOT WORK!**

**THIS SOFTWARE REVISION HAS A MORE ADVANCED PROGRAMMING METHOD. THE UPPER (HEATING WATER) SENSOR JACK IS USED TO ANSWER "YES" OR TO INCREASE A VALUE. THE LOWER (DOMESTIC WATER) SENSOR JACK IS USED TO ANSWER "NO" OR TO DECREASE A VALUE. ALL "YES/NO" QUESTIONS ARE ENDED WITH A "?". ENTERING A "YES" TO A QUESTION, WILL CHANGE THE ITEM FROM ITS CURRENT SETTING. TO THAT WHICH IS SHOWN ON THE SCREEN. ANSWERING "NO" OR ALLOWING THE 7 SECOND DELAY TO EXPIRE WILL ADVANCE YOU TO THE NEXT SELECTION. WHEN CHANGING A TIME OR TEMPERATURE VALUE YOU WILL PLUG INTO THE TOP JACK TO INCREASE THE VALUE OR THE LOWER JACK TO DECREASE THE VALUE. REMOVE THE SENSOR PLUG WHEN THE DESIRED VALUE IS REACHED, AND THE VALUE WILL BE SAVED. IF YOU DO NOTHING, AND ALLOW THE 7 SECOND DELAY TO EXPIRE, THE PROGRAM WILL ADVANCE YOU TO THE NEXT PROGRAMMABLE PARAMETER.**

**YOU HAVE SEVEN (7) SECONDS TO RESPOND TO ANY OF THE DISPLAY PROMPTS.**

**PROGRAMMING MAY BE STOPPED OR ABORTED AT ANY TIME BY TURNING THE CONTROLLER OFF. ANY PARAMETERS THAT WERE CHANGED WILL REMAIN CHANGED.**

#### Entering Configuration Mode:

To enter configuration mode, the controller must be powered up without any sensors connected. When prompted insert a water sensor plug into the TOP sensor jack (HEATING WATER). To confirm, remove the plug when prompted. The unit will then indicated that it has entered "\*\*\*Config Mode\*\*". After a 4 second delay the display will advance to the first programmable parameter.

**Any changes made to a programmable parameter will be confirmed by indicating " \*\*DATA SAVED\*\*".**

#### RESET DEFAULTS?

This is a Yes/No type of parameter

This parameter will reset all of the programmable parameters to factory defaults. It will not clear any of the timer/counter accumulators. Plug into the top jack to perform the desired function, or plug into the lower jack to answer NO (and proceed to the next parameter, or allow the 7 second delay to expire and proceed to the next parameter).

#### VIEW COUNTERS?

This is a Yes/No type of parameter

This parameter will allow you to view all of the time and counter accumulators. Plug into the top jack to perform the desired function, or plug into the lower jack to answer NO (and proceed to the next parameter, or allow the 7 second delay to expire and proceed to the next parameter).

**RESET TIMERS?**

This is a Yes/No type of parameter

**WARNING:** This parameter will clear ALL of the time and counter accumulators. Plug into the top jack to perform the desired function, or plug into the lower jack to answer NO (and proceed to the next parameter, or allow the 7 second delay to expire and proceed to the next parameter).

**For all of the parameters that follow, after making a change and the “\*\*DATA SAVED\*\*” message is displayed, you will be given an additional chance to change that parameter again, before advancing to the next programmable parameter.**

**PREPURGE=xxx SEC**

This is an Increase/Decrease type of parameter

This parameter indicates the pre-purge time currently programmed into the controller (default value = 000 seconds). To change this setting, plug in the sensor to the appropriate jack to increase or decrease the value.

**FOR DEGREES C?**

OR

**FOR DEGREES F?**

This is a Yes/No type of parameter

The controller will prompt you to change to whatever value is NOT currently selected (default value = F). For example, if the parameter is currently set for degrees F, the only choice will be to change to degrees C. This setting will alter the indicated values of the next two (2) programmable parameters, and how the indicated temperatures are displayed when the controller is in operation. Plug into the top jack to change the parameter, or plug into the lower jack to answer NO (and proceed to the next parameter, or do nothing and allow the 7 second delay to expire and proceed to the next parameter).

**HLOLIM = xxx °F**

OR

**HLOLIM = xxx °C**

This is an Increase/Decrease type of parameter

This parameter is used by the controller to set the low-limit temperature for the heating water. When the heating water temperature goes below this setting, “HEATING/LOLIM” will be displayed, and the controller will no longer attempt to achieve any savings and will return control to the operating-control. To change this setting, plug the sensor into the appropriate jack to increase or decrease the value. The indicated value will be what is currently set in the controller (default = Auto). When in “AUTO” and only the heating water sensor is used, the default value of 120°F / 49°C will be used. When in “Auto” and both sensors are used the default value of 145°F / 62°C will be used. To change this setting, plug the sensor into the appropriate jack to increase or decrease the value. The range of adjustment is between 90°F/32°C and 180°F/82°C. Remove the sensor when the desired value is reached.

**DLOLIM = xxx °F**

OR

**DLOLIM = xxx °C**

This is an Increase/Decrease type of parameter

This parameter is used by the controller to set the low-limit temperature for the domestic hot water. When the domestic water temperature goes below this setting, “HEATING/LOLIM” will be displayed, and the controller will no longer attempt to achieve any savings and return control to the operating-control. To change this setting, plug the sensor into the appropriate jack to increase or decrease the value. The indicated value will be what is currently set in the controller (default = 120°F / 49°C). The range of adjustment is between 90°F/32°C and 180°F/82°C. Remove the sensor when the desired value is reached.

**ECON TIMER OFF?**

OR

**ECON TIMER ON?**

This is a Yes/No type of parameter

This parameter controls whether or not the Economizer Time accumulator is displayed. The controller will prompt you to change to whatever value is NOT currently selected (default value = ON). For example, if the parameter is currently set for “ON”, the only choice will be to change to “OFF”. Note – the accumulator is active even if not displayed. Plug into the top jack to change the parameter, or plug into the lower jack to answer NO (and proceed to the next parameter, or do nothing and allow the 7 second delay to expire and proceed to the next parameter).

**RUN TIME OFF?**

OR

**RUN TIME ON?**

This is a Yes/No type of parameter

This parameter controls whether or not the Burner Run-Time accumulator is displayed. The controller will prompt you to change to whatever value is NOT currently selected (default value = ON). For example, if the parameter is currently set for “ON”, the only choice will be to change to “OFF”. Note – the accumulator is active even if not displayed. Plug into the top jack to change the parameter, or plug into the lower jack to answer NO (and proceed to the next parameter, or do nothing and allow the 7 second delay to expire and proceed to the next parameter).

**A SAVING OFF?**

OR

**A SAVING ON?**

This is a Yes/No type of parameter

This parameter controls whether or not the Average Savings accumulator is displayed. The controller will prompt you to change to whatever value is NOT currently selected (default value = ON). For example, if the parameter is currently set for “ON”, the only choice will be to change to “OFF”. Note – the accumulator is active even if not displayed. Plug into the top jack to change the parameter, or plug into the lower jack to answer NO (and proceed to the next parameter, or do nothing and allow the 7 second delay to expire and proceed to the next parameter).

**MAX ECON=xxx MIN**

OR

**MAX ECON=DISABLD**

This is an Increase/Decrease type of parameter

This parameter limits the maximum amount of time that the controller is allowed to remain in the Economizer Mode. To change this setting, plug the sensor into the appropriate jack to increase or decrease the value. The indicated value will be what is currently set in the controller (default = DISABLED). The range of this adjustment is between 10 and 120 minutes and “DISABLED”. Remove the sensor when the desired value is reached. If the controller goes in to the heating mode as a result of this feature, the message “HEATING/MAX ECON” will be displayed.

**MAX STBY = xxx MIN**

OR

**MAX STBY=DISABLD**

This is an Increase/Decrease type of parameter This feature of the controller is to limit the maximum amount of time that the controller is allowed to remain in the Standby Mode as a means of monitoring the internal electronics against failure. If a heating call is not sensed within the prescribed time period, the timer will expire and the control will take itself out of the circuit (fail-safe). A period (“.”) will be appended to the “STANDBY MODE.” message to indicate that this timer has expired for service personnel. It will only reset upon sensing a call from the aquastat. Cycling power to the control will NOT reset the timer.

To change this setting, plug in the sensor when prompted. The indicated value will be what is currently set in the controller (default = 180 minutes). The range of this adjustment is between 45 and 180 minutes and “DISABLED”. Remove the sensor when the desired value is reached. **Disabling this function is NOT recommended!**

This condition is not necessarily a fault. It will occur naturally if the heating system has been “off” or there are long periods of time between aqua-stat heating calls. The only time that this should be considered a problem is if the controller is in “STANDBY MODE.” and the burner is running. This would indicate a failure of the on-board electronics and that the IntelliCon has taken itself out of the circuit.

**AFTER THE LAST PARAMETER IS REACHED THERE WILL BE A BRIEF DELAY AND THE CONTROLLER WILL RESET. DURING THIS TIME THE SENSOR(S) SHOULD BE RECONNECTED OR THE CONTROLLER WILL ATTEMPT TO GO INTO THE CONFIGURATION MODE AGAIN. IF YOU DON'T REACT QUICKLY ENOUGH, SIMPLY TURN THE CONTROLLER OFF, CONNECT THE SENSOR(S) AND TURN THE CONTROLLER BACK ON.**

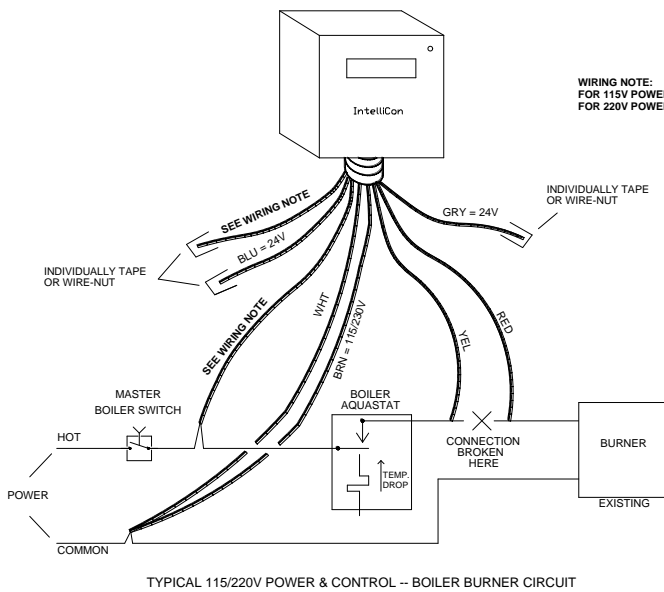

Fig. 1a

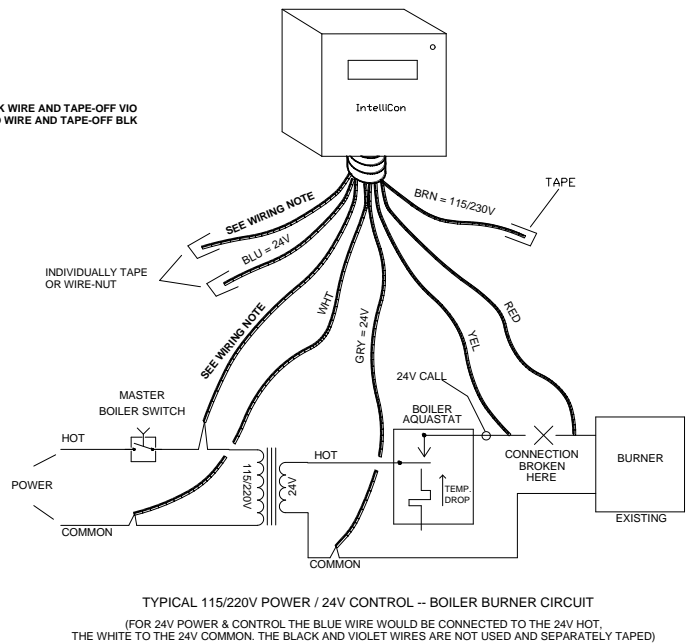

Fig. 1b

**WIRING NOTE:** The IntelliCon unit has MULTI-VOLTAGE capability and has separate common wires for the Power and Control circuits. It is necessary that these wires be connected to the appropriate commons for the circuit or the unit will not function properly. Unused wires **MUST** be separately taped!  
**IMPROPER VOLTAGE SELECTION WILL DAMAGE THE UNIT and Void the Warranty.**

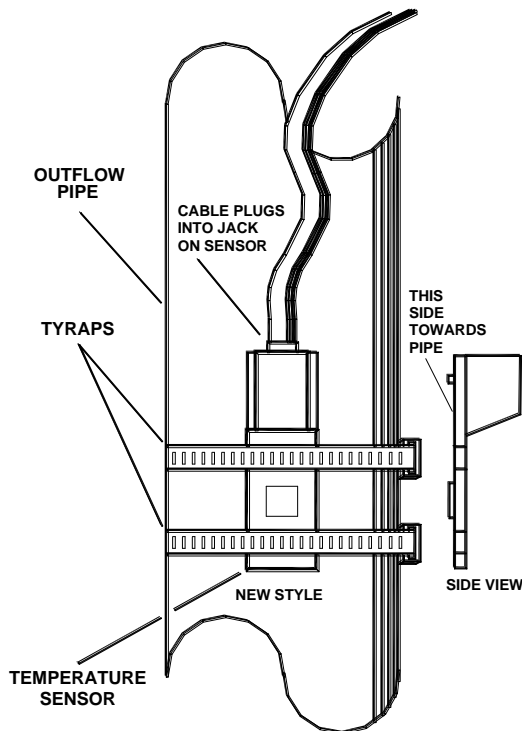

Fig. 2

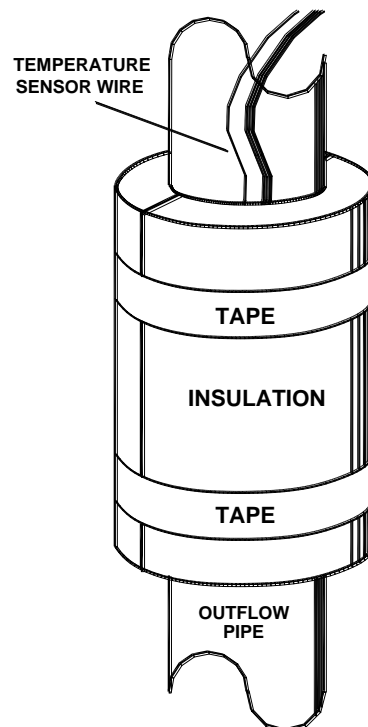

Fig. 3